

Link-Belt Centrik-Lok CL Series

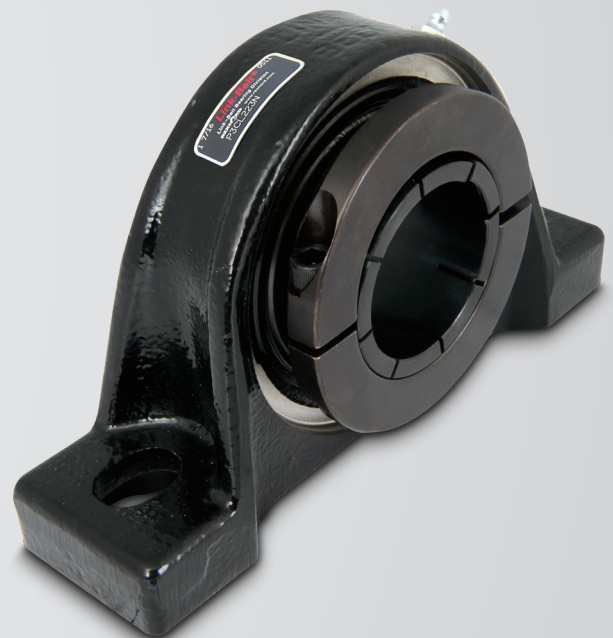



Rexnord proudly introduces an improved design for concentric locking mounted ball bearings. Utilized in demanding applications that require superior holding force, concentric locking provides straightforward installation for longer bearing life and performance.

Link-Belt's new Centrik-Lok® CL design features eight gripping tabs to solve the toughest shaft mounting problems. Its unique split collar design utilizes a high-strength socket head cap screw for secure and easy installation. The locking collar yields superior axial holding force, which is 20% greater than the next best competitor.

Features and Benefits

Concentric Eight Tab Design

- 360° concentricity for high speed/high vibration applications
- Shaft marring: minimal to none
- Will not fracture during installation



High Strength Socket Head Cap Screws

- Deep pockets to minimize socket marring
- Industry standard cap screws

Anti-Rotation Pin

- Prevents the turning of the outer ring in high vibration applications

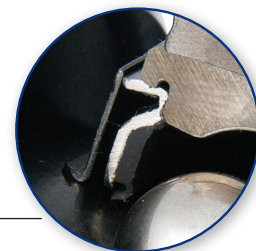
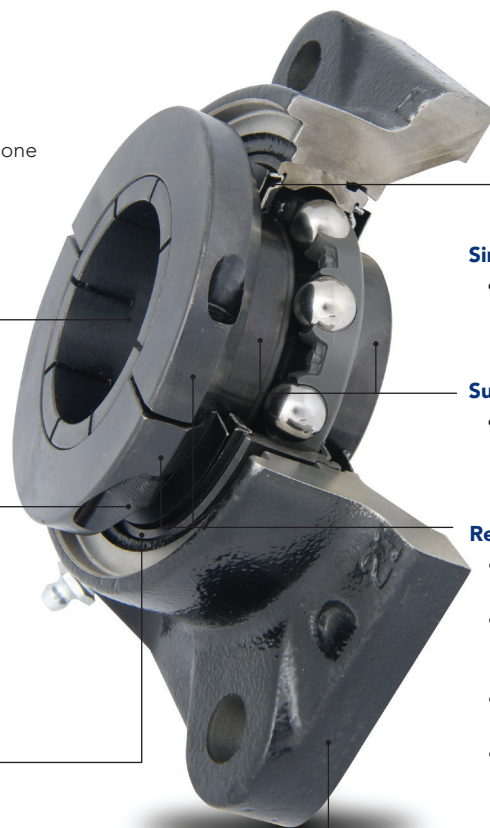

Single Lip Seal with Flinger

- Optional Steel Labyrinth (speed) and triple lip seals (contamination)

Superior Finished Raceways

- Precision ground and super-finished; cool running and quiet

Retained Two-Piece Collar Design

- Maximum holding force on undersized shafting (up to $-0.004''$)
- Unique retention feature keeps locking collar attached to bearing during installation
- 20% greater gripping power than comparable bearings
- Simple installation

Corrosion Resistant Black Powder Coated Housing Unit

Seal Types

All bearing type seals are crimped tightly in the bearing outer rings with steel flingers and cannot be blown out during relubrication.

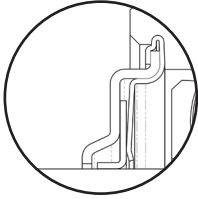

Seal Type "H" (Labyrinth)

Multi-labyrinth seal with contoured external flinger is an excellent all-purpose, low friction seal for grease lubrication.

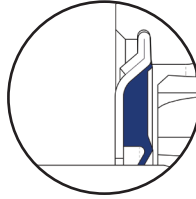

Seal Type "N" (Single Lip Contact)

Type N lip seals have the same contoured external flinger for maximum lip protection and a full land riding lip for grease retention and dirt exclusion. The type N seal rides on a precision ground surface of the bearing inner ring for smooth operation and tightness.



Seal Type "E3" (Triple Lip Contact)

Triple lip seal is a tight, high-torque seal for ultimate dirt exclusion. It has an external flinger to protect the precision die molded lip members.

Accommodates Commercial Grade Shafting

- 1/2" – 2" nominal to -.003"
- 2 1/8" – 4" nominal to -.004"

General Bearing Information

- Races – precision-ground and super-finished
- Housings – powder-coated cast iron
- Grease – multi-purpose lithium complex
- Black Oxide – corrosion resistance

Mounting Type

- Centrik-Lok "CL" with 360° Shaft Mounting

Housing Options

- Tap Base Pillow Block
- Pillow Block
- Flange: 2-bolt and 4-bolt flange
- Take-up
- Piloted Flange

Shaft Sizes

- 1/2" – 4"

End Cap (Standard Duty only)

- Press Fit



Load Ratings, Speed Limits

Standard Duty

Size Code	Static load rating (lbs)	Dynamic load rating (lbs)	H and N seal speed limit	E3 seal speed limit
203	1,110	2,040	12000	N/A
204	1,480	2,480	10000	N/A
205	1,760	2,680	9600	1000
206	2,530	3,720	8000	N/A
207	3,440	4,900	6850	700
208	4,460	6,240	6000	650
209	4,590	6,250	5330	600
210	5,220	6,610	4800	550
211	6,570	8,290	4360	500
212	8,080	10,030	4000	450
213	9,010	10,940	3850	400
215	11,100	12,650	2,900	350
217	14,300	15,920	2,950	300
220	20,900	23,350	2,500	N/A

Medium Duty

Size Code	Static load rating (lbs)	Dynamic load rating (lbs)	H and N seal speed limit
206	2,530	3,720	8000
207	3,440	4,900	6850
208	4,460	6,240	6000
209	4,590	6,250	5330
210	5,220	6,610	4800
211	6,570	8,290	4360
212	8,080	10,030	4000
214	8,620	11,890	3,050
215	8,460	11,870	2,900
216	11,400	14,800	2,700
218	14,400	18,350	2,400



Industries served

Aggregates
Agriculture
Air Handling
Construction
Package Handling
Shipping

Standard Duty

P3CL200N



Photo Shows a 2-Bolt
Ball Bearing Pillow Block Unit

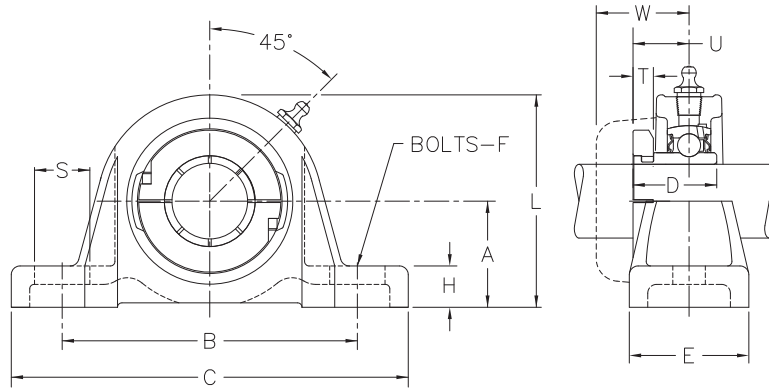

Dimensions

Size Code	Shaft Diameter	Part Number	A Base to Centerline Height	B Distance Between Bolt Holes	C	D	E	F	H	L	M	S	U	W	Approx. Weight
203	1/2	P3CL2B08N *■	1 3/16	3 1/2	4 5/8	1 3/32	1 1/2	3/8	1/2	2 11/32	-	3/4	41/64	1 13/64	1.00
	5/8	P3CL210N *■													0.45
	11/16	P3CL211N *■													1.70
204	17.00	P3CL2M17N *■	30.16	88.90	117.50	27.78	38.10	10.00	12.70	59.50	-	19.00	16.30	30.60	0.45
	3/4	P3CL212N *■	1 5/16	3 7/8	5 1/8	1 9/32	1 1/2	3/8	1/2	2 19/32	-	11/16	3/4	1 19/64	1.70
	20.00	P3CL2M20N *■	33.34	98.40	130.20	32.54	38.10	10.00	12.70	65.90	-	17.50	19.00	32.90	0.76
205	7/8	P3CL214N Δ*■	1 7/16	4	5 3/8	1 23/64	1 5/8	3/8	9/16	2 7/8	-	11/16	51/64	1 9/32	1.90
	15/16	P3CL215N Δ*■													0.86
	1	P3CL216N Δ*■													2.70
206	25.00	P3CL2M25N Δ*■	36.51	101.60	136.50	34.53	41.30	10.00	14.30	73.00	-	17.50	20.20	32.50	0.86
	1 1/8	P3CL218N *■	1 11/16	4 5/8	6 5/16	1 9/16	1 3/4	1/2	11/16	3 5/16	-	15/16	61/64	1 29/64	2.70
	1 3/16	P3CL219N *■													1.22
1 1/4	P3CL2E20N *■	3.70													
207	30.00	P3CL2M30N *■	42.86	117.50	160.30	39.69	44.40	12.00	17.50	84.10	-	23.80	24.20	36.90	1.22
	1 1/4	P3CL220N Δ*■	1 7/8	4 15/16	6 3/8	1 49/64	1 7/8	1/2	13/16	3 11/16	-	13/16	1 7/64	1 35/64	3.70
	1 3/8	P3CL222N Δ*■													1.67
1 7/16	P3CL223N Δ*■	2.12													
208	35.00	P3CL2M35N Δ*■	47.62	125.40	161.90	44.85	47.60	12.00	20.60	93.70	-	20.60	28.20	39.30	1.67
	1 1/2	P3CL224N Δ*■	2	5 3/8	7 1/16	1 29/32	1 7/8	1/2	13/16	4	-	15/16	1 11/64	1 41/64	4.70
	40.00	P3CL2M40N Δ*■													2.12
1 5/8	P3CL226N Δ*■	5.40													
209	1 11/16	P3CL227N Δ*■	2 1/8	5 5/8	7 1/4	2 1/32	2	1/2	13/16	4 5/16	-	7/8	1 15/64	1 21/32	5.40
	1 3/4	P3CL228N Δ*■													2.43
	45.00	P3CL2M45N Δ*■													2.43

Product Features

- Corrosion resistant powder coating
- Cast iron housing
- Broad range of sealing options
- Wide inner ring for increased shaft stability
- Centrik-Lok CL shaft locking device
- Alignable and relubricatable
- Black Oxide

Size Code	Shaft Diameter	Part Number	A Base to Centerline Height	B Distance Between Bolt Holes	C	D	E	F	H	L	M	S	U	W	Approx. Weight
210	1 15/16	P3CL231N Δ*■	2 1/4	6 3/16	7 7/8	2 3/32	2 1/8	5/8	7/8	4 1/2	-	15/16	1 17/64	1 25/32	6.10
	2	P3CL2E32N Δ*■													
	50.00	P3CL2M50N Δ*■													
211	2	P3CL232N Δ*■	2 1/2	6 3/4	9 1/16	2 1/4	2 3/8	5/8	1	5	-	1 5/16	1 13/32	2 1/64	7.80
	2 3/16	P3CL235N Δ*■													
	55.00	P3CL2M55N Δ*■													
212	2 1/4	P3CL236N Δ*■	2 11/16	7 1/2	9 1/2	2 1/2	2 1/2	5/8	1 1/8	5 3/8	-	1 1/16	1 9/16	2 7/64	11.40
	2 3/8	P3CL238N Δ*■													
	2 7/16	P3CL239N Δ*■													
	60.00	P3CL2M60N Δ*■													
213	2 1/2	P3CL240N Δ*	3	8 1/8	10 1/2	2 3/4	2 7/8	3/4	1 5/16	6	4 51/64	1 3/16	1 3/4	2 15/64	15.90
	2 11/16	P3CL243N Δ*													
	65.00	P3CL2M65N Δ*													
215	2 3/4	P3CL244N Δ*	3 1/4	8 7/8	11 3/4	2 59/64	3 1/4	3/4	1 3/8	6 1/2	5 1/4	1 5/16	1 27/32	2 29/64	19.50
	2 15/16	P3CL247N Δ*													
	3	P3CL2E48N Δ*													
	75.00	P3CL2M75N Δ*													
217	3 7/16	P3CL255N Δ*	3 3/4	10	13	3 39/64	3 1/2	7/8	1 5/8	7 7/16	5 23/32	1 5/8	2 11/64	2 57/64	28.70
	3 1/2	P3CL2E56N Δ*													
	85.00	P3CL2M85N Δ*													
220	3 15/16	P3CL263N *	4 7/16	11 7/8	15 1/4	4 7/64	4 1/4	7/8	1 13/16	8 7/8	6 1/2	1 7/8	2 7/16	3	50.20
	4	P3CL2E64N *													
	100.00	P3CL2M100N *													

Please call 1-866-REXNORD for availability

* N lip seals with flingers standard

Lubrication fitting tap size: for size code 203, 1/4 in-28 UNF: for all other size codes, 1/8 in PT

Base to centerline tolerance, +0.000 in/-0.010 in (+0.00 mm/-0.25 mm)

■ Available with H labyrinth seals

Δ Available with E3 triple lip seals

Nickel plated housings available through all size codes, add suffix K75

Standard Duty

PT3CL200N



Photo Shows a 2-Bolt Ball Bearing Tapped Base Pillow Block

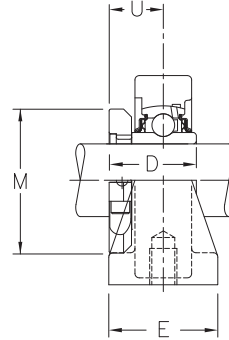
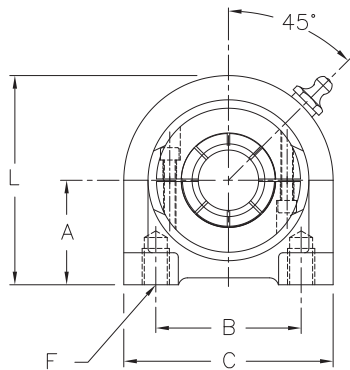

Product Features

- Corrosion-resistant powder coating
- Cast iron tapped base housing
- Broad range of sealing options
- Wide inner ring for increased shaft stability
- Spring locking setscrew mount
- Alignable & relubricatable
- See Features & Benefits for additional info.

Dimensions

Size Code	Shaft Diameter	Part Number	A Base to Centerline Height	B Distance Between Bolt Holes	C	D	E	F Depth	F Tap	L	N	U	Approx. Weight
204	3/4	PT3CL212N *■	1 5/16	2	2 7/8	1 11/32	1 1/2	1/2	3/8-16	2 19/32	1 15/16	13/16	1.20
	7/8	PT3CL214N *Δ■											
205	15/16	PT3CL215N *Δ■	1 7/16	2	2 7/8	1 3/8	1 1/2	1/2	3/8-16	2 7/8	2 5/64	57/64	1.40
	1	PT3CL216N *Δ■											
206	1 1/8	PT3CL218N *■	1 11/16	3	4	1 9/16	1 1/2	5/8	7/16-14	3 5/16	2 15/32	29/32	2.50
	1 3/16	PT3CL219N *■											
207	1 1/4	PT3CL2E20N *■											
	1 1/4	PT3CL220N *Δ■											
	1 3/8	PT3CL222N *Δ■	1 7/8	3 1/4	4 13/32	1 3/4	2	3/4	1/2-13	3 11/16	2 7/8	1 1/32	3.40
209	1 7/16	PT3CL223N *Δ■											
	1 11/16	PT3CL227N *Δ■	2 1/8	3 3/4	5	1 61/64	2	7/8	1/2-13	4 1/4	3 17/64	1 7/32	4.90
210	1 3/4	PT3CL228N *Δ■											
	1 15/16	PT3CL231N *Δ■	2 1/4	4	5 7/16	2 5/64	2	7/8	5/8-11	4 1/2	3 5/8	1 21/64	5.60
	2	PT3CL2E32N *Δ■											

Please call 1-866-REXNORD for availability

Lubrication fitting tap size, 1/8 in PT

Base to centerline tolerance, +.000 in/-.010 in (+0.00 mm/-0.25 mm)

* N lip seals with flingers standard

■ Available with H labyrinth seals

Δ Available with E3 triple lip seals

Nickel plated housings available through all size codes, add suffix K75

FX3CL200N

Product Features

- Corrosion resistant powder coating
- Cast iron housing
- Broad range of sealing options
- Wide inner ring for increased shaft stability
- Centrik-Lok CL shaft locking device
- Alignable and relubricatable
- Black Oxide

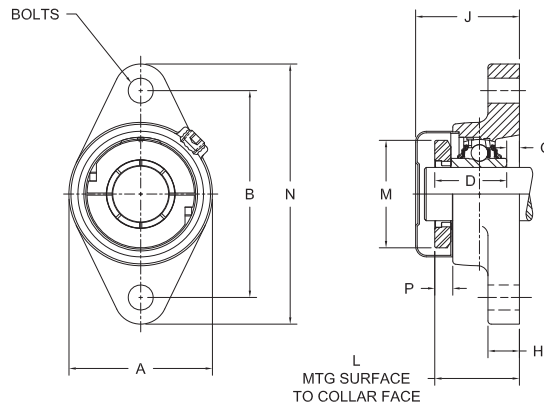

Photo Shows a 2-Bolt Ball Bearing Flanged Unit

Dimensions

Size Code	Shaft Diameter	Part Number	B Distance Between Bolt Holes	L Mounting Surface to Collar Face	A	D	F	G	H	J	M	N	P	Approx. Weight	
204	3/4	FX3CL212N*■	3 17/32	1 9/16	2 7/16	1 11/32	3/8	13/64	9/16	2 1/16	1 59/64	4 13/32	3/8	1.20	
	20.00	FX3CL2M20N*■	89.69	39.90	61.90	34.04	10.00	5.20	14.30	52.30	48.77	111.90	9.53	0.54	
205	7/8	FX3CL214N*Δ	3 57/64	1 17/32	2 11/16	1 3/8	7/16	3/16	19/32	2 1/16	2 5/64	4 29/32	3/8	1.60	
	15/16	FX3CL215N*Δ													
	1	FX3CL216N*Δ	25.00	FX3CL2M25N*Δ	98.82	38.90	68.30	34.80	10.00	4.80	15.10	52.30	52.83	124.60	9.53
206	1	FX3CL2B16N*■	4 19/32	1 47/64	3 3/16	1 9/16	7/16	11/64	19/32	2 1/4	2 15/32	5 19/32	27/64	2.40	
	1 1/8	FX3CL218N*■													
	1 3/16	FX3CL219N*■													30.00
207	1 1/4	FX3CL2E20N*■	5 1/8	1 29/32	3 5/8	1 3/4	1/2	5/32	5/8	2 25/64	2 7/8	6 1/8	1/2	3.00	
	1 3/8	FX3CL222N*Δ													
	1 7/16	FX3CL223N*Δ													
	35.00	FX3CL2M35N*Δ													130.18
208	1 7/16	FX3CL2B23N*Δ	5 21/32	2 1/8	4	1 15/16	1/2	11/64	5/8	2 37/64	3 3/64	6 25/32	35/64	4.20	
	1 1/2	FX3CL224N*Δ													
	1 5/8	FX3CL2E26N*Δ													40.00
209	1 1/2	FX3CL2B24N*Δ	5 27/32	2 1/8	4 1/4	1 61/64	1/2	7/64	5/8	2 19/32	3 17/64	7 3/32	33/64	5.10	
	1 5/8	FX3CL226N*Δ													
	1 11/16	FX3CL227N*Δ													
	1 3/4	FX3CL228N*Δ													45.00
210	1 11/16	FX3CL2B27N*Δ	6 3/16	2 7/16	4 9/16	2 5/64	9/16	19/64	3/4	2 59/64	3 5/8	7 7/16	39/64	6.30	
	1 3/4	FX3CL2B28N*Δ													
	1 7/8	FX3CL230N*Δ													
	1 15/16	FX3CL231N*Δ													
210	2	FX3CL2E32N*Δ	4 9/16	6 3/16	2 5/64	9/16	19/64	3/4	2 59/64	2 7/16	3 5/8	7 7/16	39/64	6.30	
	50.00	FX3CL2M50N*Δ	115.90	157.16	52.58	14.00	7.50	19.00	75.00	62.00	92.20	188.90	15.24	2.84	
211	1 15/16	FX3CL2B31N*Δ	5	7 1/4	2 15/64	5/8	13/32	13/16	3 11/64	2 21/32	3 29/32	8 1/2	21/32	7.40	
	2	FX3CL232N*Δ													
	2 3/16	FX3CL235N*Δ													
	2 1/4	FX3CL2E36N*Δ													55.00

Please call 1-866-REXNORD for availability
 Lubrication fitting tap size: for size code 203, 1/4 in-28 UNF; for all other size codes, 1/8 in PT
 * N lip seals with flingers standard
 ■ Available with H labyrinth seals
 Δ Available with E3 triple lip seals
 Nickel plated housings available, add suffix K75

Standard Duty

F3CL200N

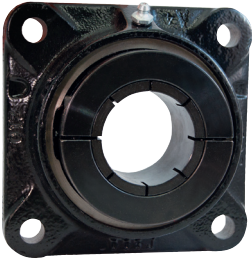
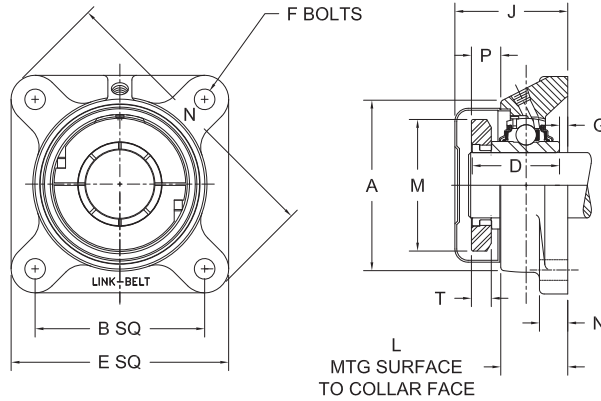

Photo Shows a 4-Bolt Ball Bearing Flanged Unit



Dimensions

Size Code	Shaft Diameter	Part Number	A	B Distance Between Bolt Holes	D	E	F	G	H	J	L Mounted Surface to Collar Face	M	N	P	Approx. Weight
204	3/4	F3CL212N*■	2 7/16	2 1/2	1 11/32	3 3/8	3/8	13/64	9/16	2 1/16	1 9/16	1 59/64	4 13/32	3/8	1.50
	20.00	F3CL2M20N*■	61.90	63.50	34.04	85.70	10.00	5.20	14.30	52.30	39.90	48.77	111.90	9.53	0.68
205	7/8	F3CL214N*Δ■	2 11/16	2 3/4	1 3/8	3 3/4	7/16	3/16	19/32	2 1/16	1 17/32	2 5/64	4 29/32	3/8	1.90
	15/16	F3CL215N*Δ■													
	1	F3CL216N*Δ■													
	25.00	F3CL2M25N*Δ■	68.30	69.85	34.80	95.20	10.00	4.80	15.10	52.30	38.90	52.83	124.60	9.53	0.86
206	1	F3CL2B16N*■	3 3/16	3 1/4	1 9/16	4 1/4	7/16	11/64	19/32	2 1/4	1 47/64	2 15/32	5 19/32	27/64	3.10
	1 1/8	F3CL218N*■													
	1 3/16	F3CL219N*■													
	1 1/4	F3CL2E20N*■													
	30.00	F3CL2M30N*■	81.00	82.55	39.62	108.00	10.00	4.40	15.10	57.20	43.90	62.48	142.10	10.72	1.40
207	1 3/16	F3CL2B19N*Δ■	3 5/8	3 5/8	1 3/4	4 5/8	1/2	5/32	5/8	2 25/64	1 29/32	2 7/8	6 1/8	1/2	3.90
	1 1/4	F3CL220N*Δ■													
	1 3/8	F3CL222N*Δ■													
	1 7/16	F3CL223N*Δ■													
	35.00	F3CL2M35N*Δ■	92.10	92.08	44.45	117.50	12.00	4.00	15.90	60.70	48.30	73.15	155.60	12.70	1.75
208	1 7/16	F3CL2B23N*Δ■	4	4	1 15/16	5 1/8	1/2	11/64	5/8	2 37/64	2 1/8	3 3/64	6 25/32	35/64	5.00
	1 1/2	F3CL224N*Δ■													
	1 5/8	F3CL2E26N*Δ■													
	40.00	F3CL2M40N*Δ■													
209	1 1/2	F3CL2B24N*Δ■	4 1/4	4 1/8	1 61/64	5 3/8	1/2	7/64	5/8	2 19/32	2 1/8	3 17/64	7 3/32	33/64	6.20
	1 5/8	F3CL226N*Δ■													
	1 11/16	F3CL227N*Δ■													
	1 3/4	F3CL228N*Δ■													
	45.00	F3CL2M45N*Δ■	108.00	104.78	49.53	136.50	12.00	2.80	15.90	65.80	53.90	82.80	180.20	13.21	2.80
210	1 11/16	F3CL2B27N*Δ■	4 1/2	4 3/8	2 5/64	5 5/8	1/2	13/64	3/4	2 53/64	2 23/64	3 5/8	7 7/16	5/8	6.90
	1 3/4	F3CL2B28N*Δ■													
	1 7/8	F3CL230N*Δ■													
	1 15/16	F3CL231N*Δ■													
	50.00	F3CL2E32N*Δ■	114.30	111.12	52.58	142.90	12.00	5.20	19.00	71.90	59.70	92.20	188.90	15.75	3.10

Product Features

- Corrosion resistant powder coating
- Cast iron housing
- Broad range of sealing options
- Wide inner ring for increased shaft stability
- Centrik-Lok CL shaft locking device
- Alignable and relubricatable
- Black Oxide

Size Code	Shaft Diameter	Part Number	A	B Distance Between Bolt Holes	D	E	F	G	H	J	L Mounted Surface to Collar Face	M	N	P	Approx. Weight
211	1 15/16	F3CL2B31N*Δ■	4 15/16	5 1/8	2 15/64	6 3/8	5/8	5/16	29/32	3 5/64	2 9/16	3 29/32	8 1/2	5/8	8.90
	2	F3CL232N*Δ■													
	2 3/16	F3CL235N*Δ■													
	2 1/4	F3CL2E36N*Δ■													
	55.00	F3CL2M55N*Δ■	125.40	130.18	56.90	161.90	16.00	7.90	23.00	78.20	65.00	99.31	215.90	15.75	4.00
212	2 3/16	F3CL2B35N*Δ■	5 3/8	5 5/8	3 1/16	6 7/8	5/8	11/32	15/16	3 23/64	2 55/64	4 11/16	9 7/32	2 1/32	11.90
	2 1/4	F3CL236N*Δ■													
	2 3/8	F3CL238N*Δ■													
	2 7/16	F3CL239N*Δ■													
	60.00	F3CL2M60N*Δ■	136.50	142.88	77.72	174.60	16.00	8.70	23.80	85.30	72.60	119.13	234.20	16.76	5.35
213	2 1/2	F3CL240N *Δ	5 7/8	2 25/32	2 3/4	2 11/16	7 3/8	1/11	3/32	3 13/64	2 21/25	4 51/64	9 13/16	5/8	14.40
	2 11/16	F3CL243N *Δ													
	65.00	F3CL2M65N *Δ													
215	2 3/4	F3CL244N *Δ	6	2 31/32	2 59/64	2 7/8	7 3/4	3/32	3/32	3 37/64	3	5 1/4	10 1/4	1 1/16	17.40
	2 15/16	F3CL247N *Δ													
	3	F3CL2E48N *Δ													
	75.00	F3CL2M75N *Δ	152.40	75.40	74.22	73.02	196.80	2.39	2.40	90.88	76.45	133.35	260.40	17.50	7.85
217	3 7/16	F3CL255N *Δ	6 3/4	3 21/32	3 39/64	3 9/16	8 9/16	4/43	3/32	4 27/64	3 20/29	5 23/32	11 3/8	3/4	25.70
	3 1/2	F3CL2E56N *Δ													
	85.00	F3CL2M85N *Δ													

Please call 1-866-REXNORD for availability

Lubrication fitting tap size: for size code 203, 1/4 in-28 UNF; for all other size codes, 1/8 in PT

* N lip seals with flingers standard

■ Available with H labyrinth seals

Δ Available with E3 triple lip seals

Nickel plated housings available, add suffix K75

Standard Duty

FC3CL200N



Photo Shows a 4-Bolt Ball Bearing Flanged Cartridge Unit

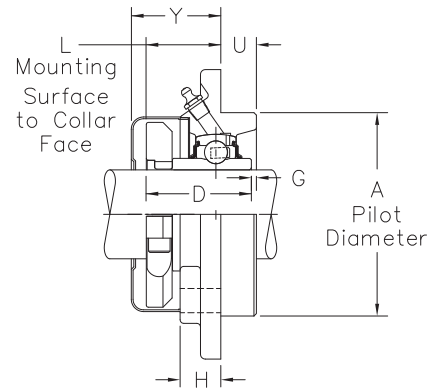
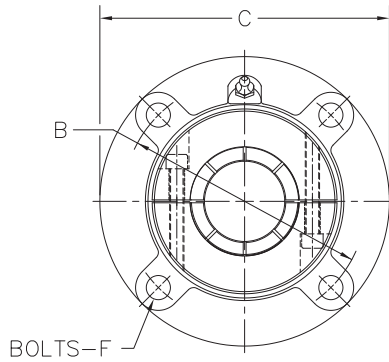

Size Code	Shaft Diameter	Part Number	A Pilot Diameter	B Bolt Hole Circle Diameter	L Mounting Surface to Collar Face	C	D	F	G	H	M	U	Y	Approx. Weight
205	7/8	FC3CL214N*Δ	3.000	3 5/8	61/64	4 3/8	1 29/64	3/8	-	5/8	2 3/32	1/2	1 29/64	3.00
	15/16	FC3CL215N*Δ												
	1	FC3CL216N*Δ												
	25.00	FC3CL2M25N*Δ	76.200	92.08	24.21	111.10	36.91	10.00	-	15.90	53.18	12.70	36.91	1.35
206	1 1/8	FC3CL218N*Δ	3.375	4 1/8	1 5/64	5	1 17/32	7/16	-	13/16	2 15/32	27/64	1 3/4	4.50
	1 3/16	FC3CL219N*Δ												
	1 1/4	FC3CL2E20N*Δ												
	30.00	FC3CL2M30N*Δ	85.720	104.78	27.38	127.00	38.89	10.00	-	20.60	62.71	10.70	44.45	2.00
207	1 1/4	FC3CL220N*Δ	3.625	4 3/8	1 13/32	5 1/4	1 47/64	7/16	3/16	1 1/16	2 57/64	15/32	2 1/64	4.60
	1 3/8	FC3CL222N*Δ												
	1 7/16	FC3CL223N*Δ												
	35.00	FC3CL2M35N*Δ	92.080	111.20	35.72	133.40	44.05	10.00	4.80	27.00	73.42	11.90	51.20	2.10
208	1 1/2	FC3CL224N*Δ	3.625	4 3/8	1 33/64	5 1/4	1 31/32	7/16	1/32	1 1/32	3 1/16	15/32	2 1/32	4.30
	40.00	FC3CL2M40N*Δ												
209	1 5/8	FC3CL226N*Δ	4.250	5 1/8	1 17/32	6 1/8	1 31/32	1/2	-	1 1/16	3 17/64	15/32	2 1/32	6.30
	1 11/16	FC3CL227N*Δ												
	1 3/4	FC3CL228N*Δ												
	45.00	FC3CL2M45N*Δ	107.950	130.18	38.89	155.60	50.01	12.00	-	27.00	82.95	11.90	51.59	2.84
210	1 15/16	FC3CL231N*Δ	4.500	5 3/8	1 19/32	6 3/8	2 5/64	1/2	11/64	1 13/64	3 5/8	5/8	2 7/16	7.40
	50.00	FC3CL2M50N*Δ												
211A	2	FC4CL232N*Δ	4.500	5 3/8	1 21/32	6 3/8	2 15/64	1/2	1/32	1 1/32	3 29/32	5/8	2 1/4	7.70
	55.00	FC4CL2M55N*Δ												
211B	2	FC3CL232N*Δ	5.000	6	1 15/32	7 1/8	2 15/64	9/16	5/32	1	3 29/32	7/8	2 1/4	9.90
	2 3/16	FC3CL235N*Δ												
	55.00	FC3CL2M55N*Δ	127.000	152.40	37.31	181.00	56.75	14.00	4.00	25.40	99.22	22.20	57.15	4.45

Product Features

- Corrosion-resistant powder coating
- Cast iron housing
- Broad range of sealing options
- Wide inner ring for increased shaft stability
- Spring locking setscrew mount
- Alignable & relubricatable
- See Features & Benefits for additional info.

Dimensions

Size Code	Shaft Diameter	Part Number	A Pilot Diameter	B Bolt Hole Circle Diameter	L Mounting Surface to Collar Face	C	D	F	G	H	M	U	Y	Approx. Weight
212	2 1/4	FC3CL236N*Δ■	5.500	6 1/2	1 39/64	7 5/8	2 19/32	9/16	-	1	4 3/16	7/8	2 1/4	12.00
	2 3/8	FC3CL238N*Δ■												
	2 7/16	FC3CL239N*Δ■	139.700	165.10	40.88	193.70	65.88	14.00	-	25.40	106.36	22.20	57.15	5.40
	60.00	FC3CL2M60N*Δ■												
213	2 1/2	FC3CL240N*Δ	6.375	7 1/2	1 7/8	8 3/4	2 3/4	5/8	3/16	1 3/16	4 51/64	1 1/16	2 23/64	17.00
	2 11/16	FC3CL243N*Δ												
	65.00	FC3CL2M65N*Δ	161.920	190.50	222.20	16.00	4.80	30.20	27.00	7.65				
215	2 3/4	FC3CL244N*Δ	6.375	7 1/2	1 55/64	8 3/4	2 29/32	5/8	3/16	1 1/16	5 1/4	1 1/4	2 23/64	17.70
	2 15/16	FC3CL247N*Δ												
	3	FC3CL2E48N*Δ	161.920	190.50	222.20	16.00	4.80	27.00	31.80	8.00				
	75.00	FC3CL2M75N*Δ												
217	3 7/16	FC3CL255N*Δ	7.375	8 5/8	2 7/16	10 1/4	3 39/64	3/4	-	1 5/8	5 23/32	1 5/32	3 1/8	34.00
	3 1/2	FC3CL2E56N*Δ												
	85.00	FC3CL2M85N*Δ	187.320	219.08	260.40	20.00	-	41.30	29.40	15.30				
220	3 15/16	FC3CL263N*	8.120	9 3/8	3 11/16	10 7/8	4 7/64	3/4	-	2 1/8	6 31/64	1 1/8	3 27/64	41.80
	4	FC3CL2E64N*												
	100.00	FC3CL2M100N*	206.250	238.12	276.20	20.00	-	54.00	28.60	18.80				

Please call 1-866-REXNORD for availability

Lubrication fitting tap size: for size codes 206 and below, 1/4 in-28 UNF; for all other size codes, 1/8 in PT

Pilot Diameter tolerance, +.000 in/--.002 in (+0.00 mml-0.05 mm)

Bore tolerance for mounting, +.002 in/--.000 in (+0.05 mml-0.00 mm)

* N lip seals with flingers standard

■ Available with H labyrinth seals

Δ Available with E3 triple lip seals

Nickel plated housings available through all size codes, add suffix K75

Standard Duty

TH3CL200



Photo Shows a Ball Bearing Take-Up Unit

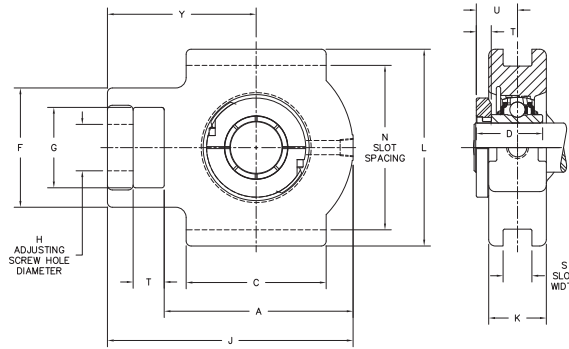

Product Features

- Corrosion resistant powder coating
- Wide slot design
- Broad range of sealing options
- Wide inner ring for shaft stability
- Centrik-Lok CL shaft locking device
- Alignable and relubricatable
- Black Oxide

Dimensions

Size Code	Shaft Diameter	Part Number	H Adjusting Screw Clearance	N Slot Spacing	S Slot Width	A	C	D	F	G	J	K	L	T	U	Y	W	Approx. Weight																
204	1/2	TH3CL2B08N*■	3/4	3	0.531	2 ²⁷ / ₃₂	2 1/4	1 11/ ₃₂	1 7/ ₈	1 1/4	3 ³¹ / ₃₂	1 1/16	3 5/ ₈	5/8	0.84	2 ²¹ / ₃₂	1 ²¹ / ₆₄	2.40																
	3/4	TH3CL212N*■																																
	20.00	TH3CL2M20N*■																	19.05	76.200	13.490	72.20	57.20	34.04	47.60	31.80	100.80	27.00	92.10	15.90	21.34	67.50	33.78	1.10
205	7/8	TH3CL214N*Δ■	3/4	3	0.531	2 ²⁹ / ₃₂	2 1/4	1 3/8	1 ²⁷ / ₃₂	1 1/4	4 1/32	1 3/32	3 5/8	5/8	0.81	2 ²¹ / ₃₂	1 ⁵ / ₁₆	2.70																
	15/16	TH3CL215N*Δ■																																
	1	TH3CL216N*Δ■																																
	25.00	TH3CL2M25N*Δ■																	19.05	76.200	13.490	73.80	57.20	34.80	46.80	31.80	102.40	27.80	92.10	15.90	20.57	67.50	33.27	1.20
206	1	TH3CL2B16N*■	7/8	3 1/2	0.531	3 ¹¹ / ₃₂	2 1/2	1 ⁹ / ₁₆	2 ³ / ₁₆	1 ⁷ / ₁₆	4 ¹⁵ / ₃₂	1 ³ / ₃₂	4 1/8	5/8	0.95	2 ²⁷ / ₃₂	1 ¹⁵ / ₃₂	3.20																
	1 1/8	TH3CL218N*■																																
	1 3/16	TH3CL219N*■																																
	1 1/4	TH3CL2E20N*■																																
	30.00	TH3CL2M30N*■																	22.23	88.900	13.490	84.90	63.50	39.62	55.60	36.50	113.50	27.80	104.80	15.90	24.13	72.20	37.34	1.45
207	1 3/16	TH3CL2B19N*Δ■	7/8	3 1/2	0.531	3 ¹¹ / ₁₆	2 3/4	1 3/4	2 ⁵ / ₁₆	1 ⁷ / ₁₆	4 ¹³ / ₁₆	1 3/16	4 1/8	5/8	1.09	2 ³¹ / ₃₂	1 ³⁷ / ₆₄	4.00																
	1 1/4	TH3CL220N*Δ■																																
	1 3/8	TH3CL222N*Δ■																																
	1 7/16	TH3CL223N*Δ■																																
	35.00	TH3CL2M35N*Δ■																	22.23	88.900	13.490	93.70	69.90	44.45	58.70	36.50	122.20	30.20	104.80	15.90	27.69	75.40	40.13	1.80
208	1 7/16	TH3CL2B23N*Δ■	1 1/8	3.969	0.688	4 ³ / ₁₆	3 1/4	1 ¹⁵ / ₁₆	2 ²⁷ / ₃₂	1 ¹⁵ / ₁₆	5 ⁹ / ₁₆	1 ⁵ / ₁₆	4 3/4	3/4	1.22	3 ¹⁵ / ₃₂	1 ⁴³ / ₆₄	5.30																
	1 1/2	TH3CL224N*Δ■																																
	1 5/8	TH3CL2E26N*Δ■																																
	40.00	TH3CL2M40N*Δ■																	28.60	100.810	17.480	106.40	82.60	49.28	72.20	49.20	141.30	33.30	120.70	19.00	30.73	88.10	42.42	2.40
209	1 1/2	TH3CL2B24N*Δ■	1 1/8	3.969	0.688	4 ³ / ₁₆	3 1/4	1 ⁶¹ / ₆₄	2 ⁷ / ₈	1 ¹⁵ / ₁₆	5 ⁹ / ₁₆	1 3/8	4 3/4	3/4	1.20	3 ¹⁵ / ₃₂	1 ¹¹ / ₁₆	5.30																
	1 5/8	TH3CL226N*Δ■																																
	1 11/16	TH3CL227N*Δ■																																
	1 3/4	TH3CL228N*Δ■																																
	45.00	TH3CL2M45N*Δ■																	28.60	100.810	17.480	106.40	82.60	49.53	73.00	49.20	141.30	34.90	120.70	19.00	30.48	88.10	42.67	2.40
210	1 11/16	TH3CL2B27N*Δ■	1 1/8	3.969	0.688	4 ⁹ / ₁₆	3 3/8	2 ⁵ / ₆₄	2 ⁷ / ₈	1 ¹⁵ / ₁₆	5 ¹⁵ / ₁₆	1 ⁴³ / ₆₄	4 3/4	3/4	1.33	3 ¹⁹ / ₃₂	1 ⁵¹ / ₆₄	6.60																
	1 3/4	TH3CL2B28N*Δ■																																
	1 7/8	TH3CL230N*Δ■																																
	1 15/16	TH3CL231N*Δ■																																
	2	TH3CL2E32N*Δ■																																
	50.00	TH3CL2M50N*Δ■																	28.60	100.810	17.480	115.90	85.70	52.58	73.00	49.20	150.80	42.50	120.70	19.00	33.53	91.30	45.72	3.00
211	1 15/16	TH3CL2B31N*Δ■	1 3/8	5.094	1.062	5 ⁷ / ₁₆	4	2 ¹⁵ / ₆₄	3 ¹⁹ / ₃₂	2 1/2	7 ⁷ / ₁₆	1 3/4	5 7/8	1 1/4	1.41	4 ²³ / ₃₂	1 ¹⁵ / ₁₆	13.50																
	2	TH3CL232N*Δ■																																
	2 3/16	TH3CL235N*Δ■																																
211	2 1/4	TH3CL2E36N*Δ■	1 3/8	5.094	1.062	5 ⁷ / ₁₆	4	2 ¹⁵ / ₆₄	3 ¹⁹ / ₃₂	2 1/2	7 ⁷ / ₁₆	1 3/4	5 7/8	1 1/4	1.41	4 ²³ / ₃₂	1 ¹⁵ / ₁₆	13.50																
	55.00	TH3CL2M55N*Δ■																	34.90	129.390	26.970	138.10	101.60	56.90	91.30	63.50	188.90	44.50	149.20	31.80	35.56	119.90	49.28	6.00
	2 3/16	TH3CL2B35N*Δ■																																
212	2 1/4	TH3CL236N*Δ■	1 3/8	5.094	1.062	5 ⁷ / ₁₆	4	3 ¹ / ₁₆	3 ¹⁹ / ₃₂	2 1/2	7 ⁷ / ₁₆	2 1/16	5 7/8	1 1/4	2.06	4 ²³ / ₃₂	2 ¹³ / ₃₂	12.90																
	2 3/8	TH3CL238N*Δ■																																
	2 7/16	TH3CL239N*Δ■																																
	60.00	TH3CL2M60N*Δ■																	34.90	129.390	26.970	138.10	101.60	77.72	91.30	63.50	188.90	52.40	149.20	31.80	52.32	119.90	60.96	5.80

Please call 1-866-REXNORD for availability
Lubrication fitting tap size, 1/8 in PT

* N lip seals with flingers standard
■ Available with H labyrinth seals

Δ Available with E3 triple lip seals
Nickel plated housings available through all size codes, add suffix K75

Product Features

- Broad range of sealing options
- Centrik-Lok shaft locking device
- Sealed & relubricatable
- Cylindrical O.D.
- O.D. mounted snap ring
- See Features & Benefits for additional info.

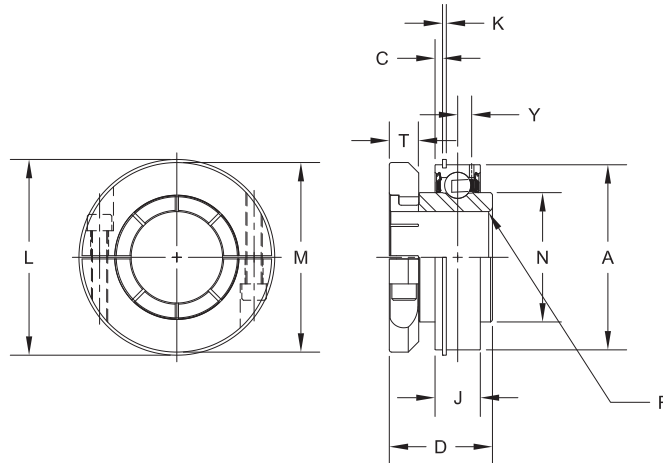

Photo Shows an ER Adapter Series Ball Bearing Unit

Dimensions

Size Code	Shaft Diameter	Part Number	B O.D.	J Outer Ring Width	L Snap Ring O.D.	C	D	G	K	M	N	R	T		Y	Approx. Weight
													Width	Tap		
204	1/2	ER8K◆□△	1.8504	0.6240	2 1/16	3/32	1 15/64	0.4050	3/64	2 1/16	1.154	0.04	23/64	#10-32	0.142	0.62
	5/8	ER10K◆●□△														0.55
	3/4	ER12K◆●□△														0.54
	20.00	ER204K◆●□△	47.0000	15.8500	52.40	2.40	30.96	10.2900	1.20	30.60	29.310	1.00	8.70	M6X1	3.610	0.20
205	7/8	ER14K◆●□△	2.0472	0.7490	2 17/64	3/32	1 13/32	0.5080	3/64	2 13/64	1.313	0.04	23/64	#10-32	0.185	0.65
	15/16	ER15K◆●□△														0.63
	1	ER16K◆●□△														0.61
	25.00	ER205K◆●□△	52.0000	19.0250	57.60	2.40	34.92	12.9000	1.20	39.70	33.350	1.00	8.70	M6X1	4.700	0.30
206	1 1/8	ER18K◆●□△	2.4409	0.8740	2 21/32	3/32	1 17/32	0.6250	3/64	2 19/32	1.587	0.04	23/64	#10-32	0.224	0.96
	1 3/16	ER19K◆●□△														0.94
	1 1/4	ER20SK◆●□△														0.90
207	1 1/4	ER20K◆●□△	2.8346	0.9365	3 5/64	1/8	1 47/64	0.6880	1/16	3 3/64	1.847	0.04	7/16	1/4-28	0.256	1.75
	1 3/8	ER22K◆●□△														1.70
	1 7/16	ER23K◆●□△														1.62
208	1 1/2	ER24K◆●□△	3.1496	1.0927	3 25/64	1/8	1 31/32	0.7500	1/16	3 3/16	2.083	0.06	7/16	1/4-28	0.297	2.18
	40.00	ER208K◆●□△	80.0000	27.7550	86.10	3.20	49.22	19.0500	1.60	63.50	52.910	1.60	11.10	M8X1.25	7.540	1.00
209	1 5/8	ER26K◆●□△	3.3465	1.0927	3 19/32	1/8	1 31/32	0.7500	1/16	3 3/8	2.281	0.06	7/16	1/4-28	0.297	2.28
	1 11/16	ER27K◆●□△														2.22
	1 3/4	ER28K◆●□△														2.15
210	1 7/8	ER30K◆●□△	3.5433	1.1240	3 25/32	1/8	2 5/64	0.7500	3/32	3 3/4	2.475	0.06	9/16	5/16-24	0.265	2.75
	1 15/16	ER31K◆●□△														2.61
211	2	ER32K◆●□△	3.9370	1.1860	4 11/64	1/8	2 15/64	0.8750	3/32	4 5/64	2.749	0.08	9/16	5/16-24	0.298	3.38
	2 3/16	ER35K◆●□△														3.07
	2 1/4	ER36K◆●□△														4.48
212	2 3/8	ER38K◆●□△	4.3307	1.2490	4 9/16	1/8	2 19/32	1.0000	3/32	4 9/32	3.012	0.08	9/16	5/16-24	0.330	4.38
	2 7/16	ER39K◆●□△														4.19
	2 1/2	ER40K◆●□△														5.92
214	2 1/2	ER40K◆●□△	4.9213	1.3740	5 9/32	5/32	2 47/64	1.0620	7/64	4 51/64	3.433	0.08	3/4	3/8-24	0.374	5.49
	2 11/16	ER43K◆●□△														6.60
215	2 7/8	ER46K◆●□△	5.1181	1.4990	5 1/2	5/32	3	1.3130	7/64	5 1/4	3.632	0.08	3/4	3/8-24	0.374	6.37
	2 15/16	ER47K◆●□△														8.05
216	3	ER48K◆●□△	5.5118	1.6865	5 7/8	5/32	3 3/8	1.3130	7/64	5 47/64	3.920	0.12	3/4	3/8-24	0.406	7.56
	3 3/16	ER51K◆●□△														

Please call 1-866-REXNORD for availability

Bearing O.D. tolerance for size code 204, +.0000 in/- .0005 in

(+0.000 mm/-0.013 mm): for size code 205 thru 208, +.0000 in/- .0006 in (+0.000 mm/-0.015 mm): for size code 209 thru 212, +.0000 in/- .0008 in (+0.000 mm/-0.020 mm): for all other size codes, +.0000 in/- .0010 in (+0.000 mm/-0.025 mm)

Lip seals standard

◆ Available with E1 viton seals for all size codes

Available with free running style seals, add suffix ● FF, □ HFF or △ MHFF for all size codes

Standard Duty

CLG200NL



Photo Shows an Unmounted Ball Bearing Unit

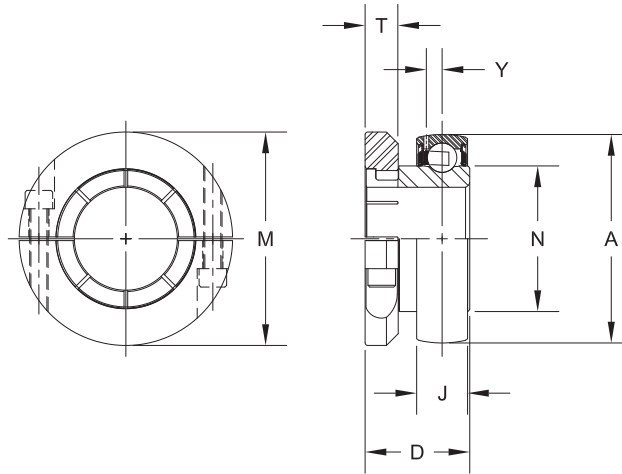

Dimensions

Size Code	Shaft Diameter	Spherical		B O.D.	D	G	M	N	r	S	T		Y	Approx. Weight
		Part Number	J Outer Ring Width								Width	Tap		
203	1/2	CLG2B08NL*■	0.5118	1.5748	1 5/32	0.4531	1 5/8	0.941	0.024	0.15	9/32	#8-32	0.158	0.25
	5/8	CLG210NL*■												
	11/16	CLG211NL*■												
	17.00	CLG2M17NL*■	13.0000	40.0000	29.37	11.5090	41.28	23.900	0.610	3.80			4.010	0.10
204	3/4	CLG212NL*■	0.5906	1.8504	1 5/16	0.5313	2 1/16	1.121	0.039	0.19	23/64	#10-32	0.176	0.50
	20.00	CLG2M20NL*■	15.0000	47.0000	33.34	13.4940	52.39	28.470	1.000	4.80			4.470	0.20
205	7/8	CLG214NL*■	0.5906	2.0472	1 29/64	0.5625	2 13/64	1.313	0.039	0.22	23/64	#10-32	0.176	0.50
	15/16	CLG215NL*Δ												
	1	CLG216NL*Δ												
	25.00	CLG2M25NL*Δ	15.0000	52.0000	36.91	14.2880	55.96	33.350	1.000	5.60			4.470	0.20
206	1 1/8	CLG218NL*■	0.7087	2.4409	1 17/32	0.6094	2 19/32	1.587	0.039	0.22	23/64	#10-32	0.202	0.80
	1 3/16	CLG219NL*■												
	1 1/4	CLG2E20NL*■												
	30.00	CLG2M30NL*■	18.0000	62.0000	38.89	15.4780	65.88	40.310	1.000	5.60			5.130	0.35
207	1 1/4	CLG220NL*Δ	0.7480	2.8346	1 47/64	0.6563	3 3/64	1.847	0.039	0.25	7/16	#1/4-28	0.239	1.20
	1 3/8	CLG222NL*Δ												
	1 7/16	CLG223NL*Δ												
	35.00	CLG2M35NL*Δ	19.0000	72.0000	44.05	16.6690	77.39	46.910	1.000	6.40			6.070	0.55
208	1 1/2	CLG224NL*Δ	0.8661	3.1496	1 31/32	0.7344	3 3/16	2.083	0.039	0.32	7/16	#1/4-28	0.253	1.50
	40.00	CLG2M40NL*Δ	22.0000	80.0000	50.01	18.6530	80.96	52.910	1.000	8.10			6.430	0.70
209	1 5/8	CLG226NL*Δ	0.8661	3.3465	1 31/32	0.7969	3 3/8	2.281	0.039	0.32	7/16	#1/4-28	0.254	2.00
	1 11/16	CLG227NL*Δ												
	1 3/4	CLG228NL*Δ												
	45.00	CLG2M45NL*Δ	22.0000	85.0000	50.01	20.2410	85.73	57.940	1.000	8.10			6.450	0.90
210	1 15/16	CLG231NL*Δ	0.8661	3.5433	2 5/64	0.8281	3 3/4	2.475	0.039	0.38	9/16	#3/8-24	0.268	2.20
	2	CLG2E32NL*Δ												
	50.00	CLG2M50NL*Δ	22.0000	90.0000	52.78	21.0340	95.25	62.860	1.000	9.60			6.810	1.00

Product Features

- Broad range of sealing options
- Wide inner ring for increased shaft stability
- Spring locking setscrew mount
- Sealed & relubricatable
- Spherical O.D.
- See Features & Benefits for additional info.

Size Code	Shaft Diameter	Spherical		B O.D.	D	G	M	N	r	S	T		Y	Approx. Weight
		Part Number	J Outer Ring Width								Width	Tap		
211	2	CLG232NL* Δ ■	0.9843	3.9370	2 ¹⁵ / ₆₄	0.8438	4 ⁵ / ₆₄	2.749	0.059	0.38	9/16	#3/8-24	0.295	2.40
	2 ³ / ₁₆	CLG235NL* Δ ■											7.490	1.10
	55.00	CLG2M55NL*Δ■											25.0000	100.0000
212	2 ¹ / ₄	CLG236NL* Δ ■	1.0630	4.3307	2 ¹⁹ / ₃₂	0.9375	4 ⁹ / ₃₂	3.012	0.059	0.38	9/16	#3/8-24	0.330	3.40
	2 ³ / ₈	CLG238NL* Δ ■											0.330	3.40
	2 ⁷ / ₁₆	CLG239NL* Δ ■											0.330	3.40
	60.00	CLG2M60NL*Δ■	27.0000	110.0000	65.88	23.8130	108.74	76.500	1.500	9.60			8.380	1.50
213	2 ¹ / ₂	CLG240NL* Δ	1.0630	4.7244	2 ³ / ₄	1.0000	4 ⁵¹ / ₆₄	3.331	-	-	3/4	#3/8-24	0.343	5.80
	2 ¹¹ / ₁₆	CLG243NL* Δ											0.343	5.80
	65.00	CLG2M65NL*Δ	27.0000	120.0000	69.85	25.4000	121.84	84.610	-	-			8.710	2.60
215	2 ³ / ₄	CLG244NL* Δ	1.1417	5.1181	2 ⁵⁹ / ₆₄	1.0625	5 ¹ / ₄	3.624	-	-	3/4	#3/8-24	0.367	7.30
	2 ¹⁵ / ₁₆	CLG247NL* Δ											0.367	7.30
	3	CLG2E48NL* Δ											0.367	7.30
	75.00	CLG2M75NL*Δ	29.0000	130.0000	74.22	26.9870	133.35	92.050	-	-			9.320	3.30
217	3 ⁷ / ₁₆	CLG255NL* Δ	1.3386	5.9055	3 ³⁹ / ₆₄	1.4375	5 ²³ / ₃₂	4.158	-	-	3/4	#3/8-24	0.415	9.50
	3 ¹ / ₂	CLG2E56NL* Δ											0.415	9.50
	85.00	CLG2M85NL*Δ	34.0000	150.0000	91.68	36.5130	145.26	105.610	-	-			10.540	4.30
220	3 ¹⁵ / ₁₆	CLG263NL*	1.5748	7.0866	4 ⁷ / ₆₄	1.6719	6 ¹ / ₂	4.913	-	-	3/4	#3/8-24	0.504	16.00
	4	CLG2E64NL*											0.504	16.00
	100.00	CLG2M100NL*	40.0000	180.0000	104.38	42.4660	165.10	124.790	-	-			12.800	7.20

Please call 1-866-REXNORD for availability

Bearing O.D. tolerance for size code 208 and below, +.0000 in/- .0005 in (+0.000 mm/-0.013 mm)

Bearing O.D. tolerance for size codes 209 thru 214, +.0000 in/- .0006 in (+0.000 mm/-0.015 mm)

Bearing O.D. tolerance for size codes 215 thru 217, +.0000 in/- .0008 in (+0.000 mm/-0.020 mm)

Bearing O.D. tolerance for all other size codes, +.0000 in/- .0010 in (+0.000 mm/-0.025 mm)

Dimension "r", max fillet radius of housing to clear bearing corner

* N lip seals with flingers standard

■ Available with H labyrinth seals

Δ Available with E3 triple lip seals

Medium Duty

MPCL200N



Photo Shows a 2-Bolt Ball Bearing Pillow Block Unit

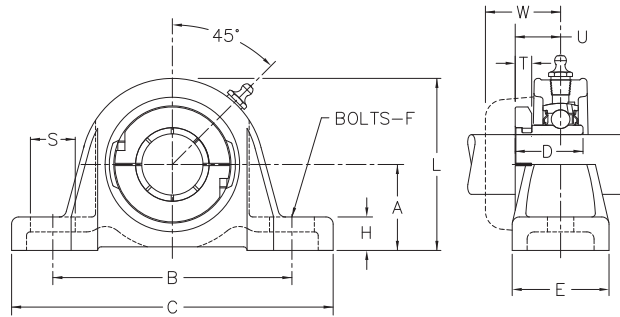

Product Features

- Corrosion-resistant powder coating
- Cast iron housing
- Broad range of sealing options
- Centrik-Lok shaft locking device
- Alignable & relubricatable
- See Features & Benefits for additional info.

Dimensions

Size Code	Shaft Diameter	Part Number	A Base to Centerline Height	B Distance Between Bolt Holes		C	D	E	F	H	L	M	U	Approx. Weight
				Min	Max									
206	1	MPCL216N◆●□△	1 11/16	4 1/8	5 1/8	6 1/4	1 5/16	1 5/8	1/2	2 1/32	3 1/4	2 19/32	2 29/32	2.54
207	1 3/16	MPCL219N◆●□△	1 7/8	4 9/16	5 9/16	6 11/16	1 31/64	1 3/4	1/2	3/4	3 11/16	3 1/16	1 1/32	3.58
208	1 7/16	MPCL223N◆●□△	2 1/8	5 1/32	6 1/32	7 1/4	1 25/32	1 7/8	1/2	7/8	4 1/8	3 3/16	1 7/32	4.65
209	1 1/2	MPCL224N◆●□△	2 1/8	5 13/32	6 17/32	7 3/4	1 25/32	2	1/2	2 9/32	4 1/4	3 3/8	1 7/32	5.40
210	1 11/16	MPCL227N◆●□△	2 1/4	5 27/32	6 27/32	8 1/4	1 51/64	2 1/8	5/8	1	4 1/2	3 3/4	1 5/16	6.53
	1 3/4	MPCL228N◆●□△												
211	1 15/16	MPCL231N◆●□△	2 1/2	6 5/16	7 1/2	8 7/8	1 57/64	2 5/16	5/8	1	4 31/32	4 3/32	1 11/32	7.87
	2	MPCL232N◆●□△												
212	2 3/16	MPCL235N◆●□△	2 3/4	6 29/32	8 5/32	9 5/8	2 5/32	2 3/8	5/8	1 1/16	5 15/32	4 9/32	1 19/32	10.24
214	2 7/16	MPCL239N◆●□△	3	7 1/2	9 1/4	10 3/4	2 5/16	2 11/16	3/4	1 5/32	6	4 13/16	1 21/32	13.31
	2 1/2	MPCL240N◆●□△												
215	2 11/16	MPCL243N◆●□△	3 1/2	8 1/8	10 1/8	12	2 23/64	2 7/8	7/8	1 7/32	6 21/32	5 1/4	1 11/16	17.36
216	2 15/16	MPCL247N◆●□△	3 1/2	8 3/8	10 1/8	12	2 25/32	3	7/8	1 9/32	6 7/8	5 47/64	2 5/64	19.32
	3	MPCL248N◆●□△												
218	3 3/16	MPCL251N◆●□△	4	9 13/16	11 15/16	14	2 19/32	3 3/8	7/8	1 11/32	7 7/8	5 47/64	1 25/32	27.52
	3 7/16	MPCL255N◆●□△												
	3 1/2	MPCL256N◆●□△												

Please call 1-866-REXNORD for availability

Lubrication fitting tap size, 1/8 in PT

Base to centerline tolerance, +/- .005 in (+/- 0.13 mm)

Lip seals standard

◆ Available with E1 viton seals

Available with free running style seals, add suffix ● FF, □ HFF or △ MHFF

Nickel plated housings available through all size codes, add suffix K75

MFXCL200N

Product Features

- Corrosion-resistant powder coating
- Cast iron housing
- Broad range of sealing options
- Centrik-Lok shaft locking device
- Alignable & relubricatable
- See Features & Benefits for additional info.

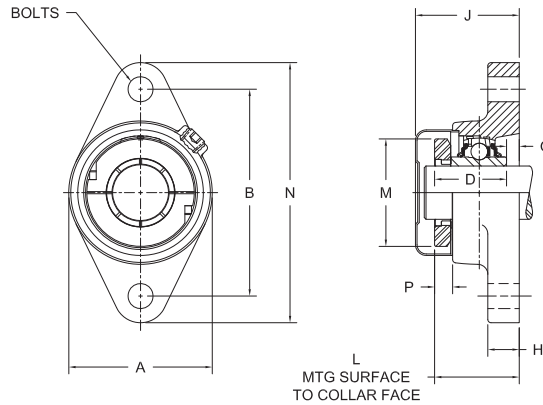

Photo Shows a 2-Bolt Ball Bearing Flanged Unit

Dimensions

Size Code	Shaft Diameter	Part Number	B Distance Between Bolt Holes	L Mounting Surface to Collar Face	A	D	F	G	H	M	N	P	Approx. Weight
206	1	MFCL216N◆□△	4 19/32	1 7/16	3 3/16	1 5/16	7/16	1/8	17/32	2 19/32	5 9/16	9/16	2.54
207	1 3/16	MFCL219N◆●□△	5 1/8	1 5/8	3 11/16	1 15/32	1/2	5/32	9/16	3 1/16	6 1/8	21/32	3.32
208	1 7/16	MFCL223N◆●□△	5 21/32	1 55/64	4 1/8	1 25/32	1/2	11/64	9/16	3 3/16	6 3/4	21/32	4.55
209	1 1/2	MFCL224N◆●□△	5 27/32	1 7/8	4 3/8	1 25/32	9/16	11/64	9/16	3 3/8	7 1/16	23/32	5.03
210	1 11/16	MFCL227N◆●□△	6 3/16	1 61/64	4 9/16	1 51/64	9/16	5/32	5/8	3 3/4	7 15/32	23/32	5.59
	1 3/4	MFCL228N◆●□△											
211	1 15/16	MFCL231N◆●□△	7 1/4	2 5/16	5	1 57/64	5/8	5/32	5/8	4 3/32	8 1/2	11/16	7.69
	2	MFCL232N◆●□△											

Please call 1-866-REXNORD for availability

Lubrication fitting tap size, 1/8 in PT

Lip seals standard

◆ Available with E1 viton seals

Available with free running style seals, add suffix ● FF, □ HFF or △ MHFF

Nickel plated housings available through all size codes, add suffix K75

Medium Duty

MFCL200N

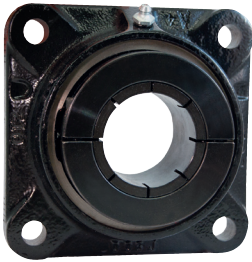
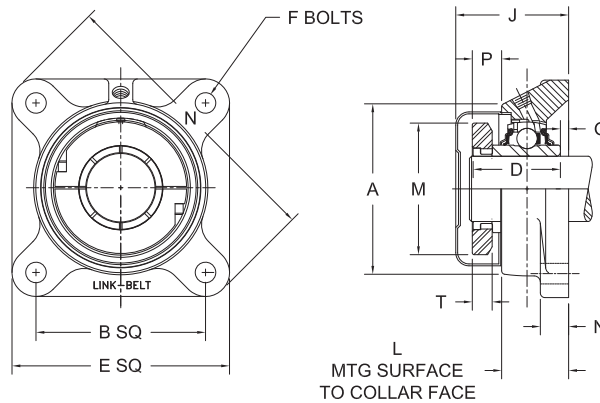

Photo Shows a 4-Bolt Ball Bearing Flanged Unit



Product Features

- Corrosion-resistant powder coating
- Cast iron housing
- Broad range of sealing options
- Centrik-Lok shaft locking device
- Alignable & relubricatable
- See Features & Benefits for additional info.

Dimensions

Size Code	Shaft Diameter	Part Number	B Distance Between Bolt Holes	L Mounting Surface to Collar Face	A	D	E	F	G	H	M	N	P	Approx. Weight
206	1	MFCL216N◆□△	3 1/4	1 7/16	3 3/16	1 5/16	4 1/4	7/16	1/8	1/2	2 19/32	5 19/32	9/16	2.54
207	1 3/16	MFCL219N◆□△	3 5/8	1 5/8	3 11/16	1 15/32	4 5/8	1/2	5/32	1/2	3 1/16	6 1/8	21/32	3.32
208	1 7/16	MFCL223N◆□△	4	1 55/64	4 1/16	1 25/32	5 1/4	1/2	11/64	9/16	3 3/16	6 25/32	21/32	4.55
209	1 1/2	MFCL224N◆□△	4 1/8	1 7/8	4 5/16	1 25/32	5 3/8	9/16	11/64	9/16	3 3/8	7 3/32	23/32	5.03
210	1 11/16	MFCL227N◆□△	4 3/8	1 61/64	4 1/2	1 51/64	5 5/8	9/16	5/32	9/16	3 3/4	7 7/16	23/32	5.59
	1 3/4	MFCL228N◆□△												
211	1 15/16	MFCL231N◆□△	5 1/8	2 5/16	5 3/16	1 57/64	6 3/8	5/8	5/32	5/8	4 3/32	8 1/2	11/16	7.69
	2	MFCL232N◆□△												
212	2 3/16	MFCL235N◆□△	5 5/8	2 3/8	5 7/16	2 5/32	6 7/8	5/8	13/64	11/16	4 9/32	9 9/32	21/32	9.34
214	2 7/16	MFCL239N◆□△	5 7/8	2 19/32	6 1/8	2 5/16	7 3/8	5/8	19/64	11/16	4 13/16	9 13/16	23/32	12.27
	2 1/2	MFCL240N◆□△												
215	2 11/16	MFCL243N◆□△	6	2 25/32	6 7/16	2 23/64	7 3/4	3/4	9/32	3/4	5 1/4	10 1/4	23/32	13.75
216	2 15/16	MFCL247N◆□△	6	3 7/64	6 3/4	2 25/32	7 3/4	3/4	21/64	13/16	5 47/64	10 1/4	11/16	15.25
	3	MFCL248N◆□△												
218	3 3/16	MFCL251N◆□△	6 3/4	2 31/32	7 3/4	2 19/32	8 7/16	3/4	3/8	15/16	5 47/64	11 1/4	11/16	21.10
	3 7/16	MFCL255N◆□△												
	3 1/2	MFCL256N◆□△												

Please call 1-866-REXNORD for availability

Lubrication fitting tap size, 1/8 in PT

Lip seals standard

◆ Available with E1 viton seals

Available with free running style seals, add suffix ● FF, □ HFF or △ MHFF

Nickel plated housings available through all size codes, add suffix K75

MFCCL200N

Product Features

- Corrosion-resistant powder coating
- Cast iron housing
- Broad range of sealing options
- Centrik-Lok shaft locking device
- Alignable & relubricatable
- See Features & Benefits for additional info.

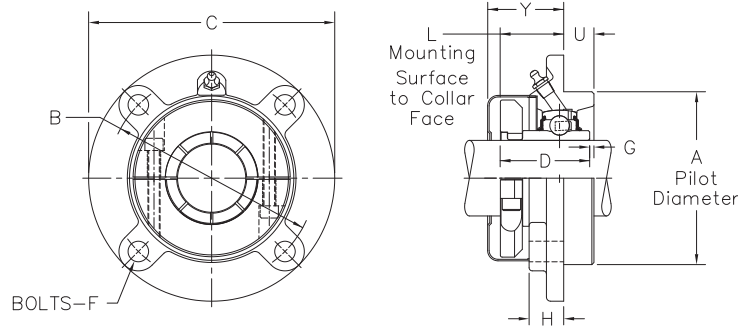

Photo Shows a 4-Bolt Ball Bearing Flanged Cartridge Unit

Dimensions

Size Code	Shaft Diameter	Part Number	A Pilot Diameter	B Bolt Hole Circle Diameter	L Mounting Surface to Collar Face	C	D	F	G & G1	H	M	U	Approx. Weight
207	1 3/16	MFCCL219N◆●□Δ	3.375	4 1/8	1 7/16	5	1 15/32	7/16	11/64	7/8	3 1/16	3/8	3.14
208	1 7/16	MFCCL223N◆●□Δ	3.625	4 3/8	1 37/64	5 1/4	1 25/32	7/16	5/32	7/8	3 3/16	7/16	3.69
209	1 1/2	MFCCL224N◆●□Δ	3.625	4 3/8	1 9/16	5 1/4	1 25/32	7/16	11/64	7/8	3 3/8	7/16	3.85
210	1 11/16	MFCCL227N◆●□Δ	4.250	5 1/8	1 21/32	6 1/8	1 51/64	1/2	11/64	7/8	3 3/4	15/32	5.72
	1 3/4	MFCCL228N◆●□Δ											
211	1 15/16	MFCCL231N◆●□Δ	4.500	5 3/8	1 39/64	6 3/8	1 57/64	1/2	15/64	7/8	4 3/32	5/8	5.96
		MFCCL232N◆●□Δ											
212	2 3/16	MFCCL235N◆●□Δ	5.000	6	1 15/16	7 1/8	2 5/32	9/16	37/64	1	4 9/32	1	8.52
214	2 7/16	MFCCL239N◆●□Δ	5.500	6 1/2	1 15/16	7 5/8	2 5/16	9/16	1/4	1	4 13/16	1	10.27
	2 1/2	MFCCL240N◆●□Δ											
215	2 11/16	MFCCL243N◆●□Δ	6.375	7 1/2	1 15/16	8 3/4	2 23/64	5/8	1/4	1	5 1/4	1	14.07
216	2 15/16	MFCCL247N◆●□Δ	6.375	7 1/2	2 17/64	8 3/4	2 25/32	5/8	11/64	1 1/8	5 47/64	1	14.28
	3	MFCCL248N◆●□Δ											
218	3 3/16	MFCCL251N◆●□Δ	7.375	8 5/8	2 1/64	10 1/4	2 19/32	3/4	5/32	1 1/8	5 47/64	1 1/8	21.90
	3 7/16	MFCCL255N◆●□Δ											
	3 1/2	MFCCL256N◆●□Δ											

Please call 1-866-REXNORD for availability

Lubrication fitting tap size, 1/8 in PT

Pilot Diameter tolerance, +.000 in/-.002 in (**+0.00 mm/-0.05 mm**)

Bore tolerance for mounting, +.002 in/-.000 in (**+0.05 mm/-0.00 mm**)

For size codes 207 & 212, use the G dimension; for all other size codes use G1

Lip seals standard

◆ Available with E1 viton seals

Available with free running style seals, add suffix ● FF, □ HFF or Δ MHFF

Nickel plated housings available through all size codes, add suffix K75

Medium Duty

MTHCL200N

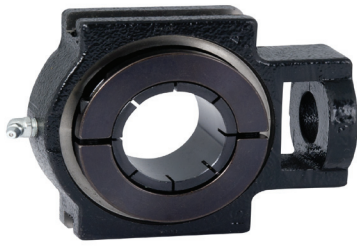
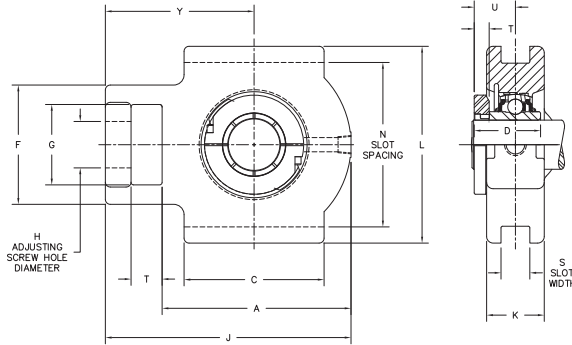

Photo Shows a Ball Bearing Take-up Unit



Product Features

- Corrosion-resistant powder coating
- Cast iron housing
- Wide slot design
- Broad range of sealing options
- Centrik-Lok shaft locking device
- Alignable & relubricatable
- See Features & Benefits for additional info.

Dimensions

Size Code	Shaft Diameter	Part Number	H Adjusting Screw Hole Diameter	N Slot Spacing	S Slot Width	A	C	D	F	G	J	K	L	M	T	U	Y	Approx. Weight
206	1	MTHCL216N◆□△	7/8	3.500	0.531	3 3/8	2 1/4	1 5/16	2 3/16	1 7/16	4 1/2	1 9/16	4 1/8	2 19/32	1 11/16	2 29/32	2 3/4	2.88
207	1 3/16	MTHCL219N◆●□△	7/8	3.500	0.531	4	2 1/2	1 31/64	2 3/8	1 7/16	5	1 9/16	4 1/8	3 1/16	1 11/16	1 1/32	3 1/16	3.20
208	1 7/16	MTHCL223N◆□□△	1 1/8	3.969	0.688	4 3/16	3 1/4	1 45/64	3 1/4	1 15/16	5 5/8	2 1/16	4 3/4	3 3/16	7/8	1 7/32	3 1/2	5.29
209	1 1/2	MTHCL224N◆●□△	1 1/8	3.969	0.688	4 3/16	3 1/4	1 45/64	3 1/4	1 15/16	5 5/8	2 1/16	4 3/4	3 3/8	7/8	1 7/32	3 7/16	4.96
210	1 11/16	MTHCL227N◆●□△	1 1/8	3.969	0.688	4 7/16	3 1/4	1 51/64	3 1/4	1 15/16	5 7/8	2 1/16	4 3/4	3 3/4	7/8	1 5/16	3 9/16	5.21
	1 3/4	MTHCL228N◆●□△																
211	1 15/16	MTHCL231N◆●□△	1 3/8	5.094	1.062	4 7/8	3 3/4	1 57/64	4	2 1/2	6 13/16	2 1/2	5 7/8	4 3/32	1 3/16	1 11/32	4 3/16	8.87
		MTHCL232N◆●□△																
212	2 3/16	MTHCL235N◆●□△	1 3/8	5.094	1.062	5 5/8	4	2 5/32	4	2 1/2	7 9/16	2 1/2	5 7/8	4 9/32	1 3/16	1 19/32	4 11/16	8.79
214	2 7/16	MTHCL239N●□△◆	1 5/8	5.906	1.062	6 19/32	4 3/4	2 5/16	4 3/8	2 3/4	8 11/16	2 3/4	6 11/16	4 13/16	1 5/16	1 21/32	5 3/8	15.09
	2 1/2	MTHCL240N●□△◆																
215	2 11/16	MTHCL243N●□△◆	1 5/8	5.906	1.062	6 27/32	4 3/4	2 23/64	4 3/8	2 3/4	8 15/16	2 3/4	6 11/16	5 1/4	1 5/16	1 7/16	5 1/2	14.87

Please call 1-866-REXNORD for availability

Lubrication fitting tap size, 1/8 in PT

Lip seals standard

◆ Available with E1 viton seals

Available with free running style seals, add suffix ● FF, □ HFF or △ MHFF

Nickel plated housings available through all size codes, add suffix K75

MCLG200NL

Product Features

- Broad range of sealing options
- Centrik-Lok shaft locking device
- Sealed & relubricatable
- Spherical O.D.
- See Features & Benefits for additional info.

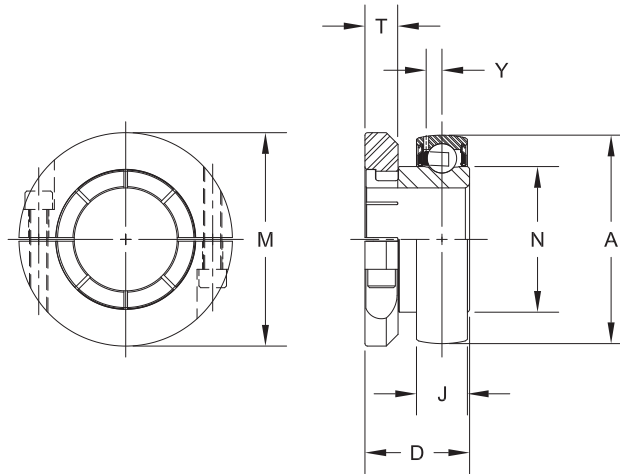

Photo Shows an Unmounted Ball Bearing Unit

Dimensions

Size Code	Shaft Diameter	Part Number	B O.D.	J Outer Ring Width	D	G	M	N	T		U	Y	Approx. Weight
									Width	Tap			
206	1	MCLG216NLPA◆●□△	2.4409	0.7087	1 ⁵ / ₁₆	0.3970	2 ¹⁹ / ₃₂	1.587	23 ³ / ₆₄	#10-32	29 ³ / ₃₂	0.202	0.92
207	1 ³ / ₁₆	MCLG219NLPA◆●□△	2.8346	0.7480	1 ¹⁵ / ₃₂	0.4420	3 ¹ / ₁₆	1.847	7 ⁷ / ₁₆	1/4-28	1 ¹ / ₃₂	0.227	1.30
208	1 ⁷ / ₁₆	MCLG223NLPA◆●□△	3.1496	0.8661	1 ²⁵ / ₃₂	0.4740	3 ³ / ₁₆	2.083	7 ⁷ / ₁₆	1/4-28	1 ⁷ / ₃₂	0.263	1.61
209	1 ¹ / ₂	MCLG224NLPA◆●□△	3.3465	0.8661	1 ²⁵ / ₃₂	0.4770	3 ³ / ₈	2.281	7 ⁷ / ₁₆	1/4-28	1 ⁷ / ₃₂	0.256	1.93
210	1 ¹¹ / ₁₆	MCLG227NLPA◆●□△	3.5433	0.8661	1 ⁵ / ₈	0.4860	3 ³ / ₄	2.475	9 ⁹ / ₁₆	5/16-24	1 ²¹ / ₆₄	0.256	2.29
	1 ³ / ₄	MCLG228NLPA◆●□△											
211	1 ¹⁵ / ₁₆	MCLG231NLPA◆●□△	3.9370	0.9843	1 ⁵⁷ / ₆₄	0.5410	4 ³ / ₃₂	2.749	9 ⁹ / ₁₆	5/16-24	1 ¹¹ / ₃₂	0.298	2.58
		MCLG232NLPA◆●□△											
212	2 ³ / ₁₆	MCLG235NLPA●□△◆	4.3307	1.0630	2 ⁵ / ₃₂	0.5820	9 ⁹ / ₃₂	3.012	9 ⁹ / ₁₆	5/16-24	1 ¹¹ / ₃₂	0.330	3.44
214	2 ⁷ / ₁₆	MCLG239NLPA●□△◆	4.9213	1.1545	2 ⁵ / ₁₆	0.6440	4 ¹³ / ₁₆	3.433	3 ³ / ₄	3/8-24	1 ¹⁹ / ₃₂	0.266	4.67
	2 ¹ / ₂	MCLG240NLPA●□△◆											
215	2 ¹¹ / ₁₆	MCLG243NLPA●□△◆	5.1181	1.1835	2 ²³ / ₆₄	0.6590	5 ¹ / ₄	3.632	3 ³ / ₄	3/8-24	1 ⁴³ / ₆₄	0.266	4.78
216	2 ¹⁵ / ₁₆	MCLG247NLPA●□△◆	5.5118	1.2575	2 ²⁵ / ₃₂	0.6960	5 ⁴⁷ / ₆₄	3.920	3 ³ / ₄	3/8-24	2 ⁵ / ₆₄	0.282	5.80
	3	MCLG248NLPA●□△◆											
218	3 ³ / ₁₆	MCLG251NLPA●□△◆	6.2992	1.3945	2 ¹⁹ / ₃₂	0.8040	5 ⁴⁷ / ₆₄	4.396	3 ³ / ₄	3/8-24	1 ²⁵ / ₃₂	0.313	8.71
	3 ⁷ / ₁₆	MCLG255NLPA●□△◆											7.63
	3 ¹ / ₂	MCLG256NLPA●□△◆											

Please call 1-866-REXNORD for availability

Bearing O.D. tolerance for size code 206 thru 208, +.0000 in/-.0005 in (+0.000 mm/-0.013 mm); for size code 209 thru 215, +.0000 in/-.0006 in (+0.000 mm/-0.015 mm); for all other size codes, +.0000 in/-.0008 in (+0.000 mm/-0.020 mm)

Lip seals standard

◆ Available with E1 viton seals

Available with free running style seals, add suffix ● FF, □ HFF or △ MHFF



Link-Belt Centrik-Lok CL Series

Normal-Duty Bearing

Frequently Asked Questions



Q. What is unique to the Link-Belt CL Series bearing?	A. The bearing inner ring has 8 gripping tabs, verses 4 tabs, that are pressed against the shaft by the unique split collar design to create maximum holding power.
Q. Is the Link-Belt CL Series a direct interchange to standard-duty ball bearing units?	A. Yes. The Link-Belt CL Series is a direct interchange with the MB 45 bearings (Centrik-Lok), for specific bore sizes.
Q. How do you know when the bearing is mounted correctly?	A. Tighten down the two-piece collar to the specified torque noted on the back of this document. These specifications are also found in the service instructions.
Q. How do you remove the Link-Belt CL Series?	A. Simply loosen the socket head cap screws and separate the two-piece collar.
Q. Are the Link-Belt CL Series bearings available in fixed and expansion options?	A. Fixed units only.
Q. Does the Link-Belt CL Series have the same speed and load ratings of the standard Link-Belt standard-duty set screw bearing?	A. Yes. The speed ratings are the same as the set screw bearing. A. No – the load ratings are actually higher than the set screw bearing by approximately 8%
Q. Can the Link-Belt CL Series accommodate "commercial grade" shafting?	A. Yes, for bore sizes 1/2" – 2" – Nominal to -0.003" A. Yes, for bore sizes 2 1/8" – 4" – Nominal to -0.004"
Q. What bore sizes are available?	A. Bore sizes 1/2" – 4" are available.

Q. Are the raceways super-finished?

A. Yes. The inner/outer races are super-finished for cool and quiet operation.

Q. What tools are required to mount the bearing?

A. Rexnord recommends using a torque wrench to tighten the socket head cap screws (see below for required socket size) to recommended torque ratings. These specifications are also found in the service instructions.

Recommended Collar Screw Torque

Screw Size	Socket Size	Inch-Pounds
#10	5/32	65 – 72
1/4	3/16	151 – 168
5/16	1/4	313 – 348
3/8	5/16	540 – 600

Q. What are the housing options?

- A. 2-bolt pillow block (standard and high backing height)
- A. 2-bolt and 4-bolt flange
- A. Take-up units
- A. Tapped base
- A. Piloted flange

Q. What seal options are available?

- A. Standard - Single-lip contact seal with flingers.
- A. Optional - Steel labyrinth clearance and triple-lip contact seal

Q. What type of retainer is used?

- A. Standard - Retainer is polymeric
- A. Optional - Steel retainer

Q. Are replacement inserts available?

A. Yes, replacement inserts are available.

Q. What is the nomenclature?

- A. P3CL2XXN (XX = bore size), P3CL231N is 1 15/16" bore size. (Bore size is in 1/16" increments)
- A. Replacement insert – CLG2xxN (xx=bore size), CLG231NL is 1 15/16" bore size

Q. Does the recommended grease re-lubrication interval change with the Link-Belt CL Series bearing in comparison to standard-duty Link-Belt Set Screw bearing?

A. No, re-lubrication intervals are the same. Re-lubrication intervals and amount of grease are based on the shaft speed and other operational conditions. See service instructions for intervals and amount of grease based on your specific application.

Q. What is the temperature range?

A. Allowable temperature range without special grease and changing of the standard internal clearance is -20°F to +225°F or 275° F with H Seal.

Q. Are end closures or covers available?

A. Yes. We have designed a durable, metal end closure that presses into the housing for a secured fit. Add "C" after the seal designation to include the cap with the bearing.



866-REXNORD/866-739-6673 (Within the US)
414-643-2366 (Outside the US)
www.rexnord.com

Why Choose Rexnord?

When it comes to providing highly engineered products that improve productivity and efficiency for industrial applications worldwide, Rexnord is the most reliable in the industry. Commitment to customer satisfaction and superior value extend across every business function.

Delivering Lowest Total Cost of Ownership

The highest quality products are designed to help prevent equipment downtime and increase productivity and dependable operation.

Valuable Expertise

An extensive product offering is accompanied by global sales specialists, customer service and maintenance support teams, available anytime.

Solutions to Enhance Ease of Doing Business

Commitment to operational excellence ensures the right products at the right place at the right time.

Rexnord Corporation

Rexnord is a growth-oriented, multi-platform industrial company with leading market shares and highly trusted brands that serve a diverse array of global end markets.

Process and Motion Control

The Rexnord Process and Motion Control platform designs, manufactures, markets and services specified, highly engineered mechanical components used within complex systems where our customers' reliability requirements and the cost of failure or downtime are extremely high.

Water Management

The Rexnord Water Management platform designs, procures, manufactures and markets products that provide and enhance water quality, safety, flow control and conservation.

REXNORD

Rex® FALK Link-Belt® marbett® MCC BERG highfield Stearns®